

ITR1205ST11A/TR

Features

- Gap : 1.1 mm
- Slit : 0.3 mm
- Compact SMD Package
- Pb/Halogens free
- The product itself will remain within RoHS complian version
- Compliance with EU REACH
- Compliance Halogen Free(Br < 900ppm, Cl < 900ppm, Br+Cl < 1500ppm)

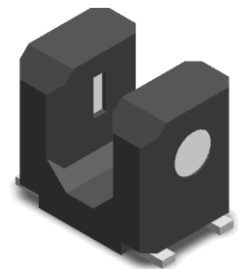

Descriptions

ITR1205ST11A/TR is an ultra small outline photo-interrupter, integrating both infrared emitter and silicon phototransistor detector with plastic molding housing.

Applications

- Printer
- Digital Camera
- Optical switch

Device Selection Guide

Device No.	Chip Material
IR	AlGaAs
PT	Silicon

TOP VIEW

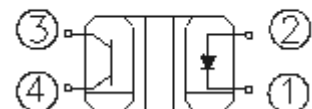

Pin Configuration

1. Cathode
2. Anode
3. Collector
4. Emitter

Package Dimensions

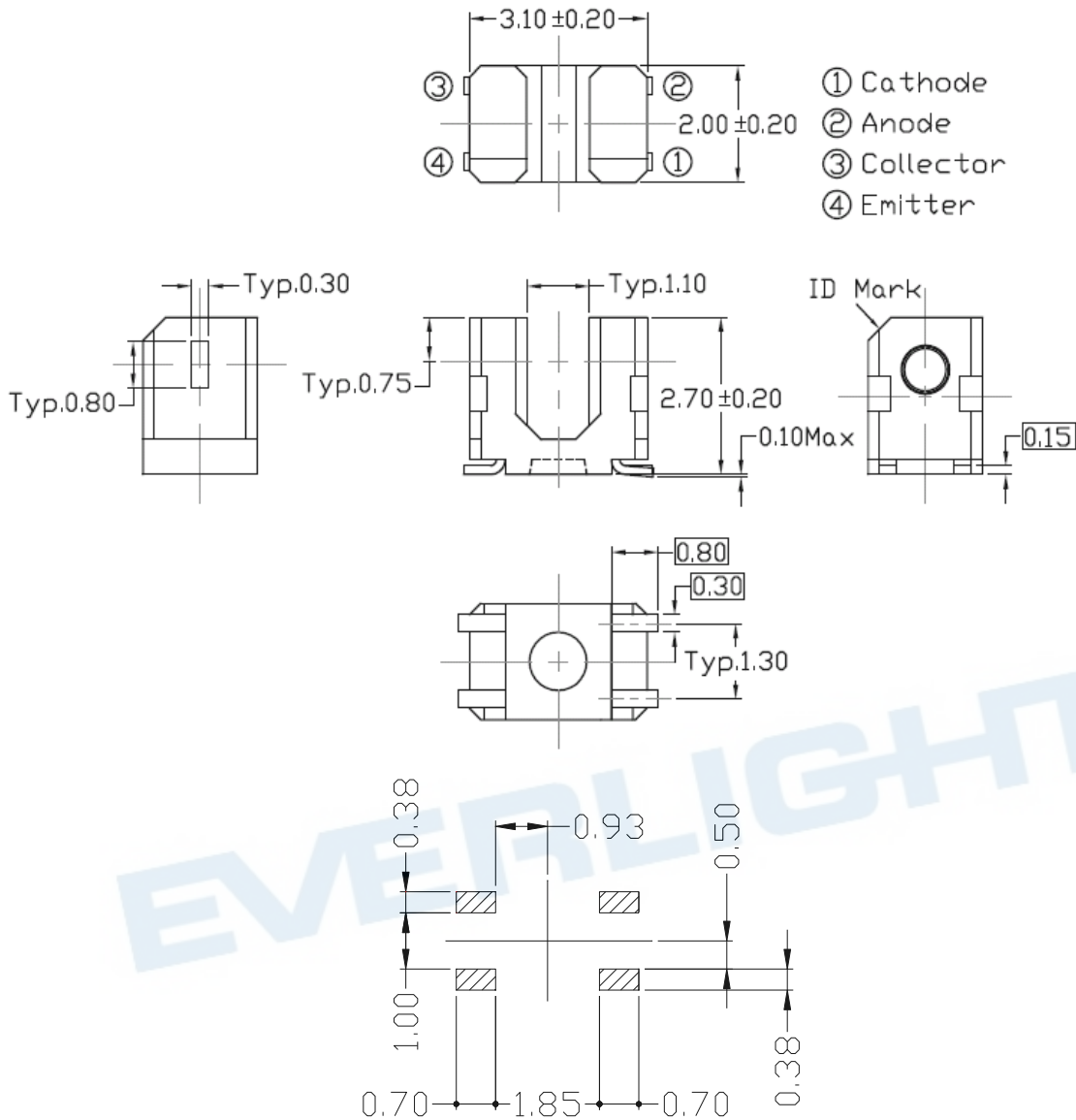

Soldering patterns

Notes:

1. All dimensions are in millimeters
2. Tolerances: $\pm 0.2 \text{ mm}$

Absolute Maximum Ratings (Ta=25°C)

Parameter		Symbol	Rating	Unit
Input	Power Dissipation at(or below) 25°C Free Air Temperature	Pd	75	mW
	Reverse Voltage	V _R	5	V
	Forward Current	I _F	50	mA
	Peak Forward Current (*1)	I _{FP}	1	A
Output	Collector Power Dissipation	P _C	75	mW
	Collector Current	I _C	20	mA
	Collector-Emitter Voltage	B V _{CEO}	35	V
	Emitter-Collector Voltage	B V _{ECO}	6	V
Operating Temperature		Topr	-40~+85	°C
Storage Temperature		Tstg	-40~+100	°C
Lead Soldering Temperature (*2)		Tsol	260	°C

Notes: (* 1) Pulse width tw=100 μsec. ,Period T=10 msec. (* 2) 2t ≤ 5 Sec

Electro-Optical Characteristics (Ta=25°C)

Parameter		Symbol	Min.	Typ.	Max.	Unit	Condition
Input	Forward Voltage	V _F	---	1.2	1.4	V	I _F =20mA
	Reverse Current	I _R	---	---	10	μA	V _R =6V
	Peak Wavelength	λ _P	---	940	---	nm	I _F =20mA
Output	Dark Current	I _{CEO}	---	---	100	nA	V _{CE} =20V
	C-E Saturation voltage	V _{CE(sat)}	---	---	0.4	V	I _C =0.05mA I _F =10mA
Transfer Characteristics	Collector Current	I _{C(ON)}	150	---	1000	μA	V _{CE} =2V I _F =5mA
	Rise time	t _r	---	9	---	μs	V _{CE} =5V I _C =1mA R _L =1KΩ
	Fall time	t _f	---	8	---	μs	

Typical Electrical/Optical/Characteristics Curves

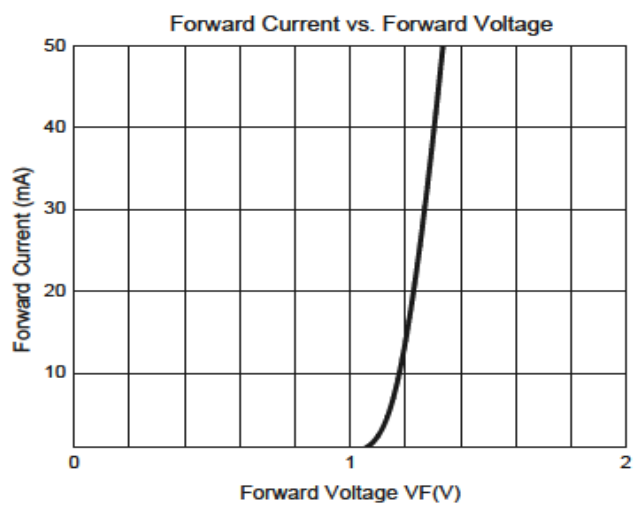
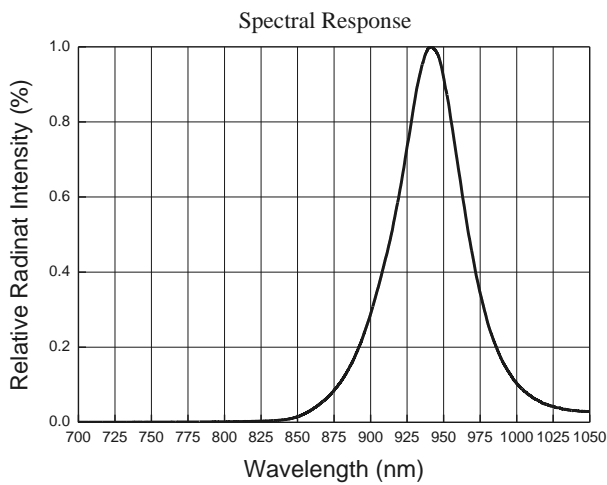
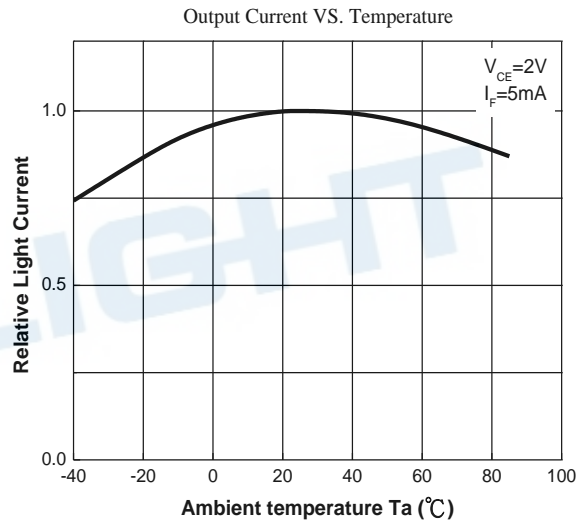
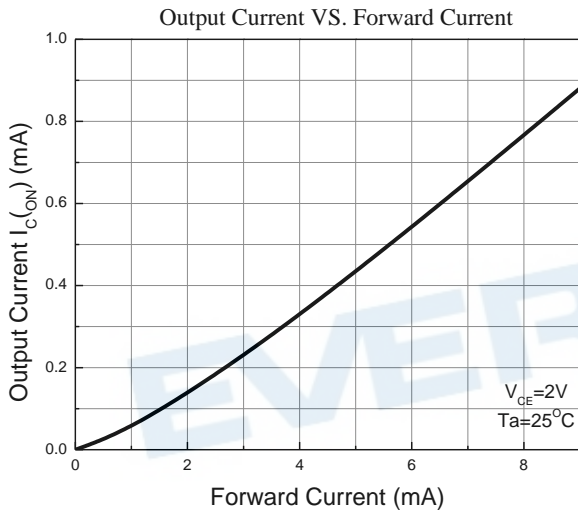
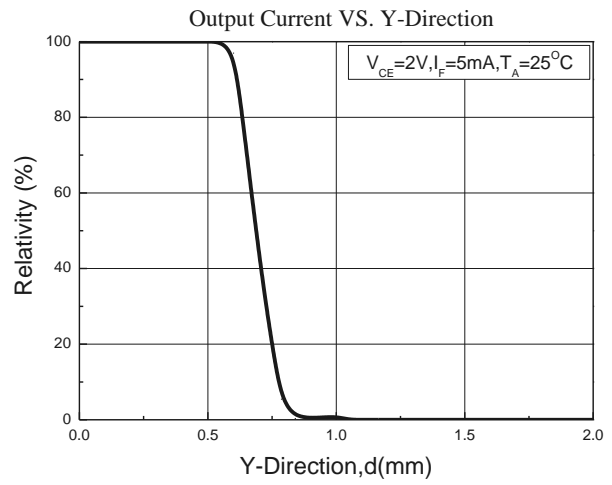
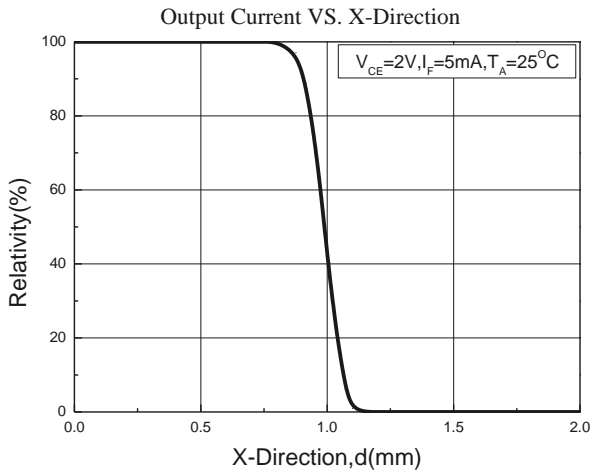

Typical Electro-Optical Characteristics Curves

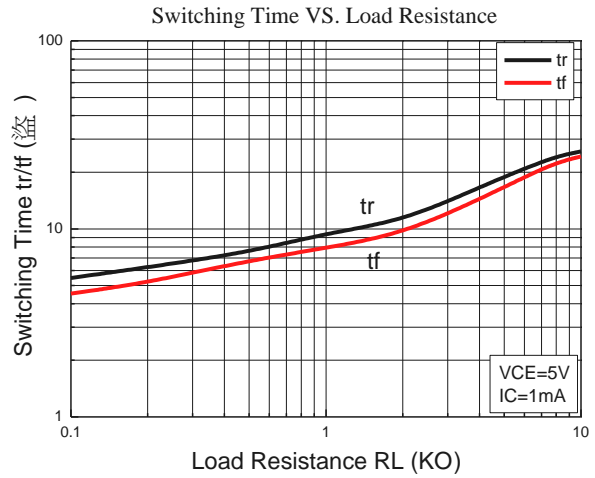
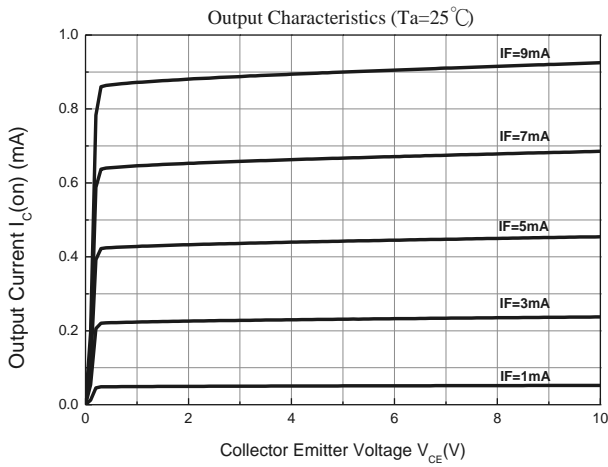

Measuring Circuit For Response Time

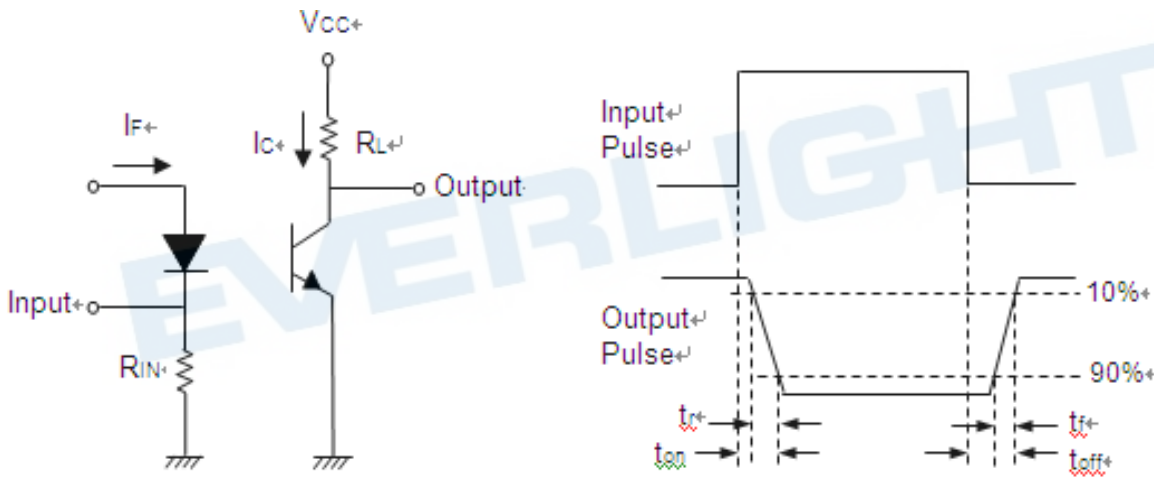

Taping Dimension

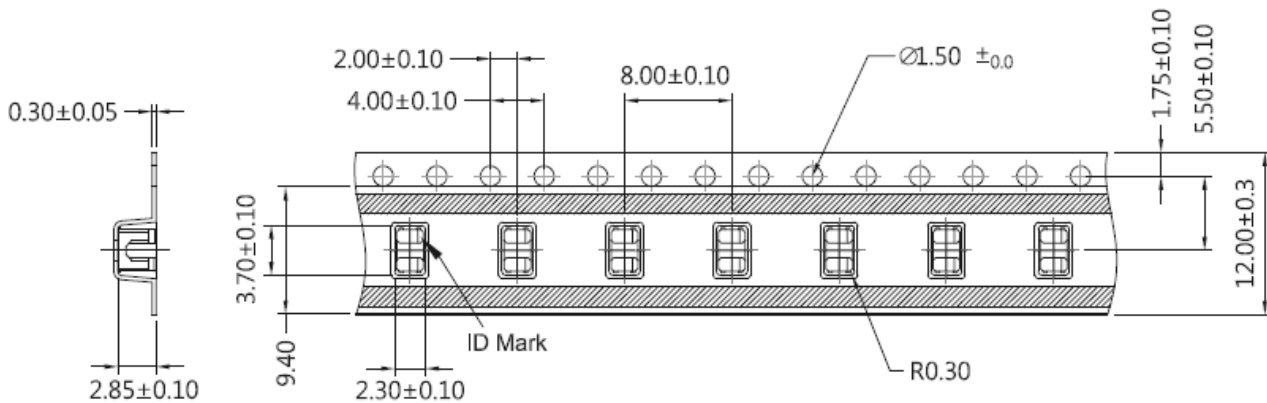

Reel Dimensions

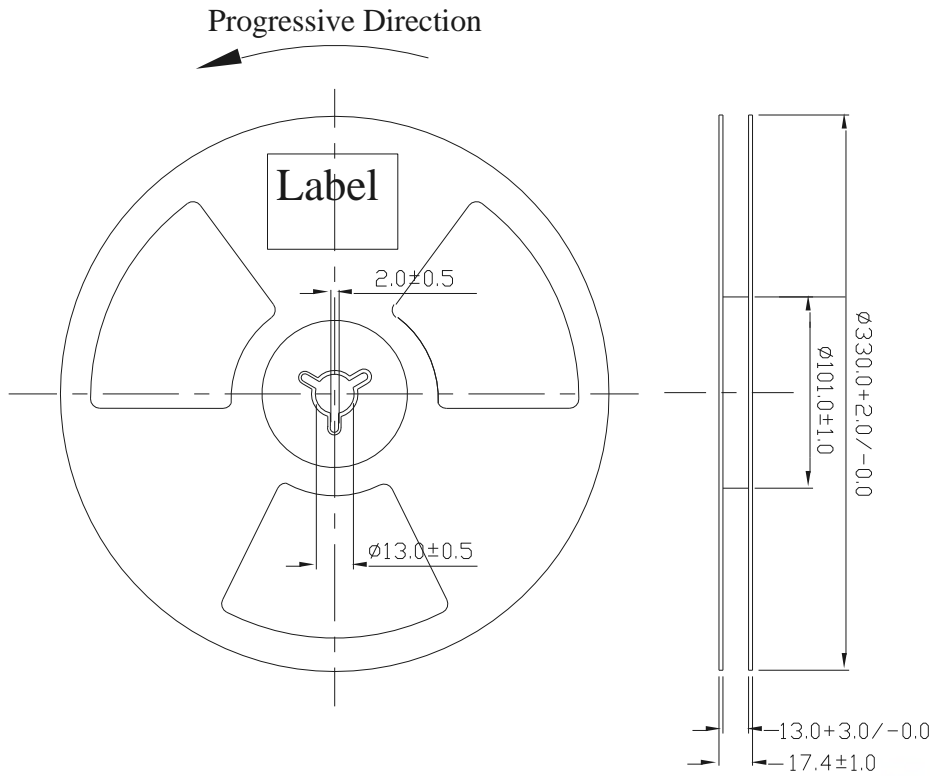

Note: The tolerances unless mentioned is ± 1.0 mm ,Unit = mm

Packing Quantity Specification

1. 3000pcs / 1 Reel
2. 13 Reels (39Kpcs) / 1 Carton

Moisture Resistant Packaging

Aluminum Moistue-Proof Bag Dimension : 400mm*375mm

Vacuum Package

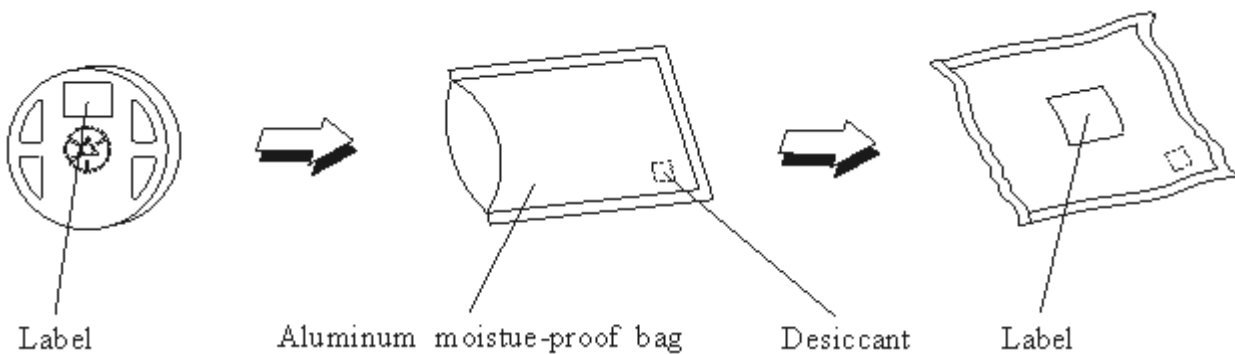

Outer Carton Dimension : 409mm(A)*245mm(B)*360mm(C)

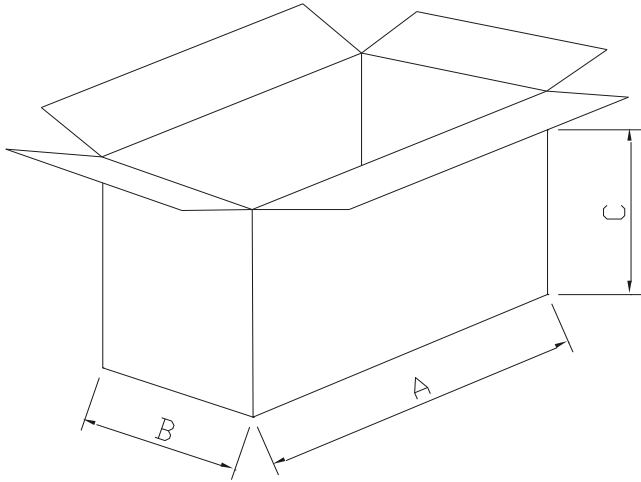

Precautions For Use

1. Storage

- 1.1 Do not open moisture proof bag before the products are ready to use.
- 1.2 Before opening the package, the device should be kept at 30°C or less and 90%RH or less.
- 1.3 The device should be used within a year.
- 1.4 After opening the package, the device should be kept at 30°C or less and 70%RH or less.
- 1.5 The device should be used within 168 hours (7 days) after opening the package.
- 1.6 If the moisture absorbent material (silica gel) has faded away or the device have exceeded the storage time, baking treatment should be performed using the following conditions.

Baking treatment : 60±5°C for 24 hours.

2. Soldering Condition

- 2.1 Pb-free solder temperature profile
- 2.2 Reflow soldering should not be done more than two times.
- 2.3 When soldering, do not put stress on the device during heating.
- 2.4 After soldering, do not warp the circuit board.

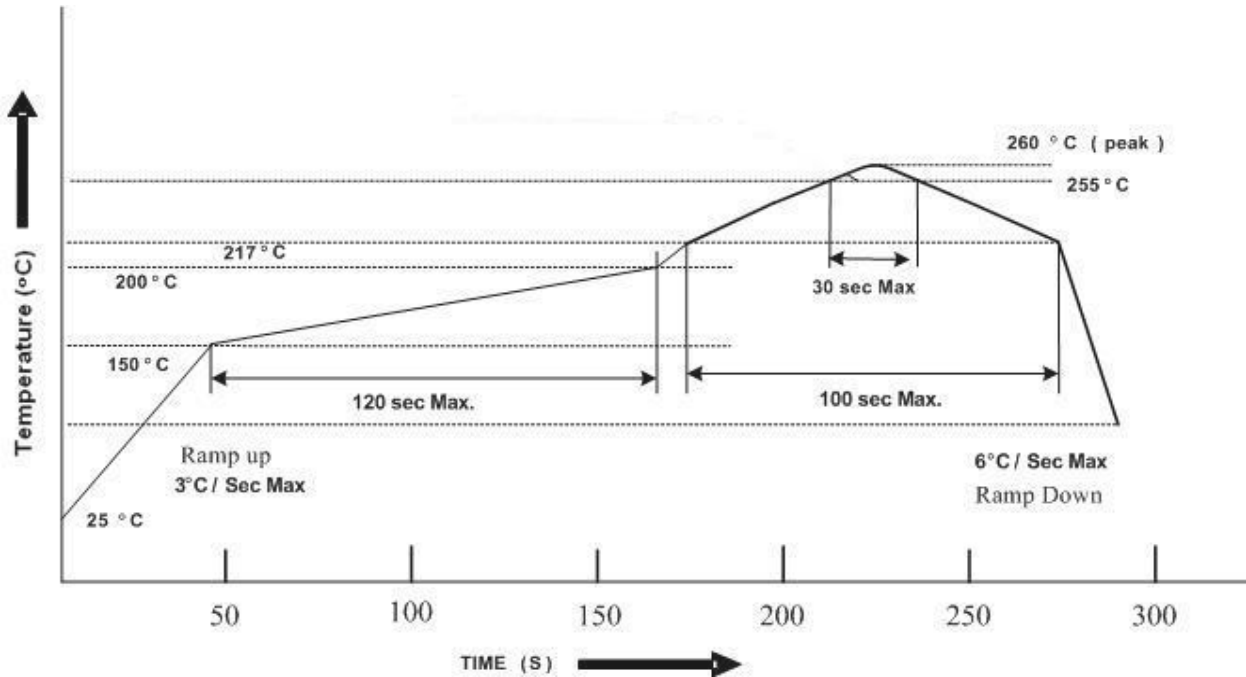

3. Soldering Iron

Each terminal is to go to the tip of soldering iron temperature less than 350°C for 3 seconds within once in less than the soldering iron capacity 25W. Leave two seconds and more intervals, and do soldering of each terminal. Be careful because the damage of the product is often started at the time of the hand solder.

4. Repairing

Repair should not be done after the device have been soldered. When repairing is unavoidable, a double-head soldering iron should be used (as below figure). It should be confirmed beforehand whether the characteristics of the device will or will not be damaged by repairing.

Label Form Specification

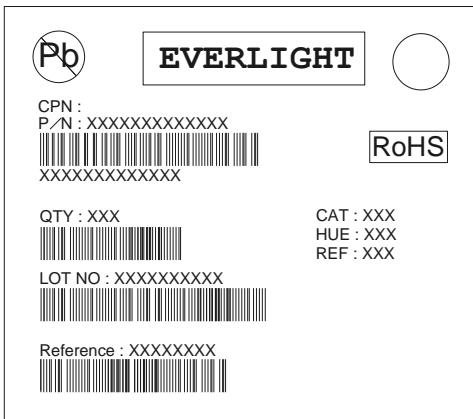

CPN: Customer's Production Number

P/N : Production Number

QTY: Packing Quantity

CAT: Ranks

HUE: Peak Wavelength

REF: Reference

LOT No: Lot Number

MADE IN TAIWAN: Production Place

Disclaimer

- 1.EVERLIGHT reserves the right(s) on the adjustment of product material mix for the specification.
- 2.The product meets EVERLIGHT published specification for a period of twelve (12) months from date of shipment.
- 3.The graphs shown in this datasheet are representing typical data only and do not show guaranteed values.
- 4.When using this product, please observe the absolute maximum ratings and the instructions for using outlined in these specification sheets. EVERLIGHT assumes no responsibility for any damage resulting from the use of the product which does not comply with the absolute maximum ratings and the instructions included in these specification sheets.
- 5.These specification sheets include materials protected under copyright of EVERLIGHT. Reproduction in any form is prohibited without obtaining EVERLIGHT's prior consent.
- 6.This product is not intended to be used for military, aircraft, automotive, medical, life sustaining or life saving applications or any other application which can result in human injury or death. Please contact authorized Everlight sales agent for special application request.